

DESIGN OF THE FUZZY CONTROL SYSTEMS BASED ON GENETIC ALGORITHM FOR INTELLIGENT ROBOTS

Gyula Mester*

University of Szeged – Faculty of Engineering
Szeged, Hungary

DOI: 10.7906/indecs.12.3.4
Regular article

Received: 31 May 2014.
Accepted: 15 July 2014.

ABSTRACT

This paper gives the structure optimization of fuzzy control systems based on genetic algorithm in the MATLAB environment. The genetic algorithm is a powerful tool for structure optimization of the fuzzy controllers, therefore, in this paper, integration and synthesis of fuzzy logic and genetic algorithm has been proposed. The genetic algorithms are applied for fuzzy rules set, scaling factors and membership functions optimization. The fuzzy control structure initial consist of the 3 membership functions and 9 rules and after the optimization it is enough for the 4 DOF SCARA Robot control to compensate for structured and unstructured uncertainty. Fuzzy controller with the generalized bell membership functions can provide better dynamic performance of the robot then with the triangular membership functions. The proposed joint-space controller is computationally simple and had adaptability to a sudden change in the dynamics of the robot. Results of the computer simulation applied to the 4 DOF SCARA Robot show the validity of the proposed method.

KEY WORDS

genetic algorithm, MATLAB environment, structure optimization, fuzzy controller, 4 DOF SCARA robot

CLASSIFICATION

ACM: D.1.1.

JEL: Z19

INTRODUCTION

In control engineering there are a number of methods to make robot manipulators work intelligently, they can be classified into: fuzzy methods, neural networks and genetic algorithms.

Genetic algorithm is an optimization technique developed by J. Holland et al. [1-2]. Genetic algorithm is one of search algorithms based on the mechanics of natural selection and natural genetics. Figure 1 shows a flow chart of the genetic algorithm.

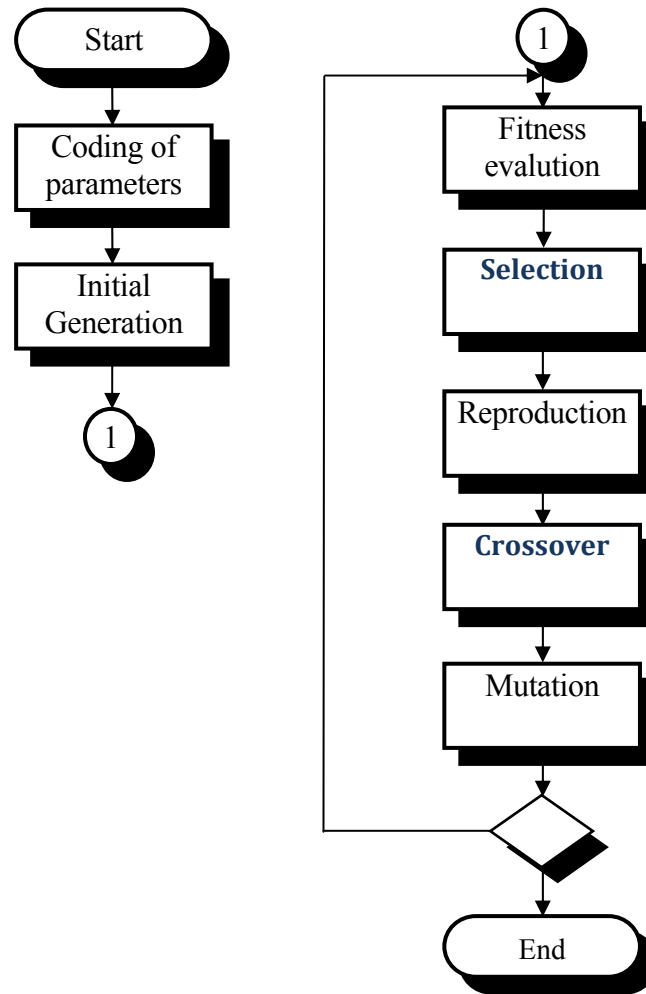

Figure 1. Flow chart of the genetic algorithm.

Genetic algorithms use the operations of selection, reproduction, crossover and mutation to generate the next generation, and they search for an optimal solution from a set of points. Recently, many genetic algorithms have been presented.

They are easy to implement and efficient for multivariable optimization problems such as fuzzy controller design.

Fuzzy systems are an attractive technique for control problems [2-4]. Fuzzy controllers are based on three well-known stages:

- the fuzzification stage,
- the rule base stage,
- the defuzzification stage,

and have been implemented in many experimental cases and in industrial applications because these controllers have advantages such as:

- easy implementation, suitability for complex dynamic systems,
- high flexibility and a
- robust nature.

The disadvantage of a fuzzy controller lies in the following:

- it is hard to obtain optimal fuzzy rules and membership functions, and
- the fuzzy set doesn't have learning capability.

To overcome those problems genetic algorithm is proposed for the purpose of auto-tuning and optimization of the structure of the fuzzy controllers.

The most important fuzzy logic parameters to be optimized are [5-13]:

- location and shape of the membership functions,
- the truth value of each rules, and
- scaling factors.

There are several ways to combine fuzzy and genetic control. Some interesting fuzzy-genetic control methods have been proposed by Fukuda and by Mester [1-2]. The genetic algorithm is a powerful tool for structure optimization of the fuzzy controllers, therefore, in this paper, integration and synthesis of fuzzy logic and genetic algorithm has been proposed.

The characteristic of the proposed system is to obtain the optimal structure of a fuzzy model.

In this article the fuzzy joint-space controller is designed using genetic algorithms without needing the knowledge of the mathematical model or the parameter values of the robot. Simple genetic algorithms are applied for fuzzy rules set, scaling factors and membership functions optimization. The proposed controller is computationally simple. Results of the computer simulation applied to the 4 DOF SCARA Robot manipulators show the advantages and the validity of the proposed method.

The article is organized as follows: Section 1 contains introduction. In Section 2, fuzzy modelling based on genetic algorithm in the MATLAB environment for intelligent robots is illustrated. The simulation results are given in Section 3 while conclusions are given in Section 4.

FUZZY MODELING BASED ON GENETIC ALGORITHM FOR INTELLIGENT ROBOTS

THE FUZZY-GENETIC INTELLIGENT CONTROL ARCHITECTURE

Recently, a new approach that combines the capability of the genetic algorithms with the simplicity of fuzzy logic has been identified as fuzzy-genetic methods. The design of self-organizing fuzzy controllers with genetic algorithm is very attractive, because the fuzzy parameters - membership functions, rules and scaling factors - can be automatically generated and tuned by observation of the process behavior. The genetic algorithm is a powerful tool for structure optimization of the fuzzy controllers, therefore, in this paper, integration and synthesis of fuzzy logic and GA has been proposed. The proposed controller supports the first order Sugeno fuzzy model (J.R. Jang at C.T. Sun) and unity weight for each rule, the single output derived by weighted average defuzzyfication [1-2]. The structure of the genetic algorithm tuned fuzzy control scheme is shown in Figure 2.

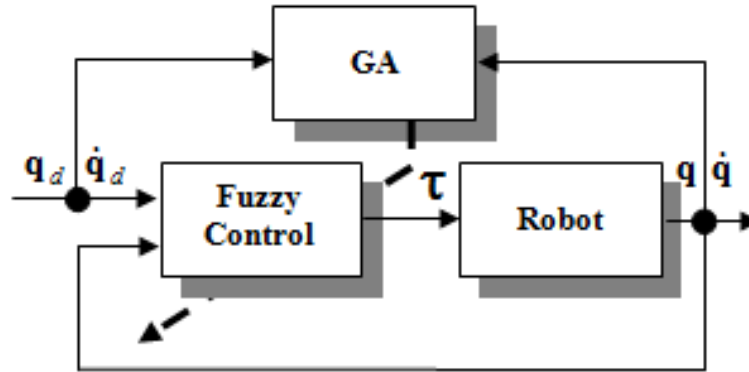

Figure 2. Genetic algorithm tuned Fuzzy Intelligent Controller scheme.

The proposed fuzzy-genetic intelligent control algorithm (FGICA) is a combined fuzzy logic with the genetic algorithm, consist of the three membership functions and nine rules, in each joint used two inputs: joint position error signal $q - q_d$, change of error signal and one output – joint torque τ . FGICA needs neither dynamic models of the system nor control experts for the robot control problem. The proposed joint-space controller is computationally simple, it is capable to compensate for structured and unstructured uncertainty, and had adaptability to a sudden change in the dynamics of the robot system. The FGICA design is initiated by using three fuzzy variables, i.e. the linguistic values NE, ZE and PO and nine rules. Generalized bell and triangular membership functions are chosen to represent the linguistic variables and fuzzy singletons for the outputs are used. The generalized bell membership function depends on three parameters $[a, b \text{ and } c]$:

$$f(x; a, b, c) = \frac{1}{1 + \left| \frac{x - c}{a} \right|^{2b}}. \quad (1)$$

where c and a denote the center and the variance of the bell-shaped function, respectively, and the parameter b is usually positive.

SUGENO FUZZY MODEL

Sugeno fuzzy model was proposed by Tagaki, Sugeno and Kang and provides a powerful tool for modelling complex systems. It can express a highly nonlinear functional relation using a small number of rules and has special defuzzifier. The Sugeno fuzzy model has the form:

$$\text{IF } x \text{ is } A \text{ and } y \text{ is } B \text{ then } z = f(x, y), \quad (2)$$

where A and B are fuzzy sets in the antecedent, and $z = f(x, y)$ is a crisp function in the consequent. When $f(x, y)$ is a first order polynomial, than the resulting fuzzy inference system is called a first-order Sugeno fuzzy model. Because each fuzzy rule has a crisp output, thus the time-consuming procedure of defuzzification is reduced.

In this article the genetic algorithm is applied for fuzzy rules set, scaling factors and membership functions optimization. The genetic algorithm starts by randomly generating initial population of strings. The generation, crossover probability and mutation probability are 200, 0,8 and 0,01, respectively. Generalized bell and triangular-shaped membership functions can be parameterized by 3 parameters. First, we optimized the fuzzy controller with the generalized bell membership functions (case 1) and then we replaced those with the triangular-shaped membership functions (case 2). In the next chapter we will compare the simulation results in the case 1 and 2.

The chromosome of the simple genetic algorithm for each robot joints includes two parts: the $3 \times 9 = 27$ consequent variables on the fuzzy control rule base (9 rules) and $2 \times 3 \times 3 = 18$ parameters of the membership functions (3 membership functions for e and 3 membership functions for de). The numbers 0, 1, 2, 3 and 4 on the fuzzy control rule table represent the linguistic values NB, NS, ZE, PS and PB, respectively. The 27 genes in the chromosome are the elements of the control rule table. In this study, the fitness function is composed of the error and the error rate of the systems step response for each joint:

$$\text{Fitness} \leftrightarrow - \sum_{i=1}^4 [k(q_{di} - q_i)^2 + (dq_{di} - dq_i)^2], \quad k = 10. \quad (3)$$

SIMULATION RESULTS

In this section, the simulation of the proposed fuzzy-genetic control scheme is presented using the 4 DOF rigid SCARA Robot. Consider a SCARA like industrial robot actuated by permanent magnet synchronous motors (Mester et al. 1992) with numerical values for parameters of the robot from [1]. Simulations time is 1 s. The desired joint trajectory is chosen to be a simple cycloidal function. Joints move simultaneously from $q_1 = 0, q_2 = q_4 = 0,5$ to $q_1 = 1, q_2 = q_4 = 1,5$ rad, and from $q_3 = 0$ to $q_3 = 0,1$ m, with a peak velocity of $\dot{q}_1 = \dot{q}_2 = \dot{q}_3 = \dot{q}_4 = 2 \text{ s}^{-1}$.

Now, the proposed fuzzy-genetic control scheme was applied to the 4 DOF SCARA robot manipulators. First we optimized the fuzzy controller with the generalized bell membership functions (case 1). In the case 2 we replaced the optimized generalized bell membership functions (case 1) with the triangular-shaped membership functions. In the next paragraph we will compare the simulation results in the cases 1 and 2. Figure 3 shows the optimized generalized bell membership functions for de_1 by the proposed method.

Figure 4 shows the replaced optimized generalized bell membership functions with the triangular membership functions for de_1 in the case 2.

Comparison of the trajectory and velocity errors on joint 1 are shown in Figures 5 and 6.

Finally, Figure 7. shows the control surface of the proposed controller as a function of the inputs for optimized generalized bell membership functions.

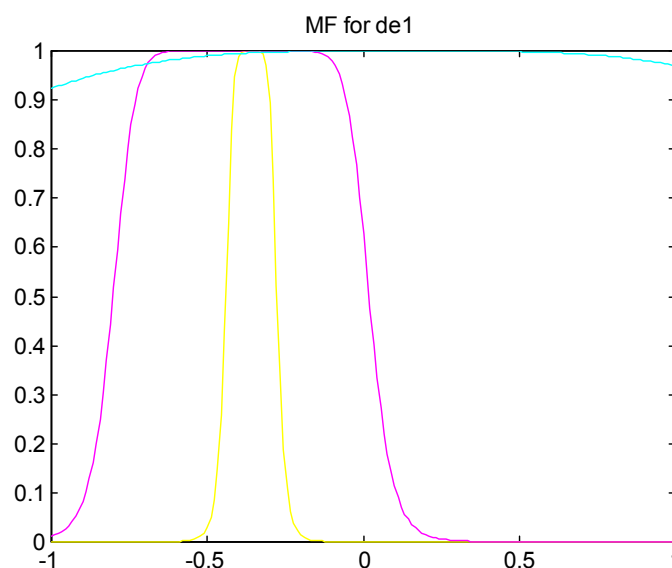

Figure 3. Optimized bell membership functions for de_1 .

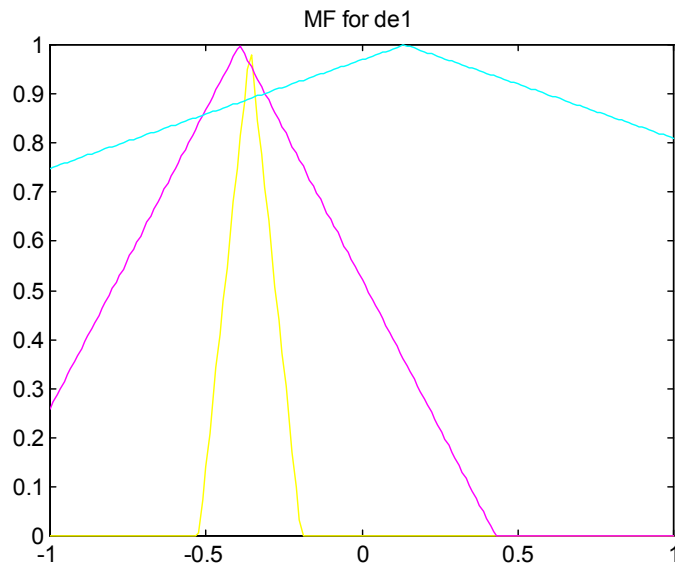

Figure 4. Triangular membership functions for de_1 .

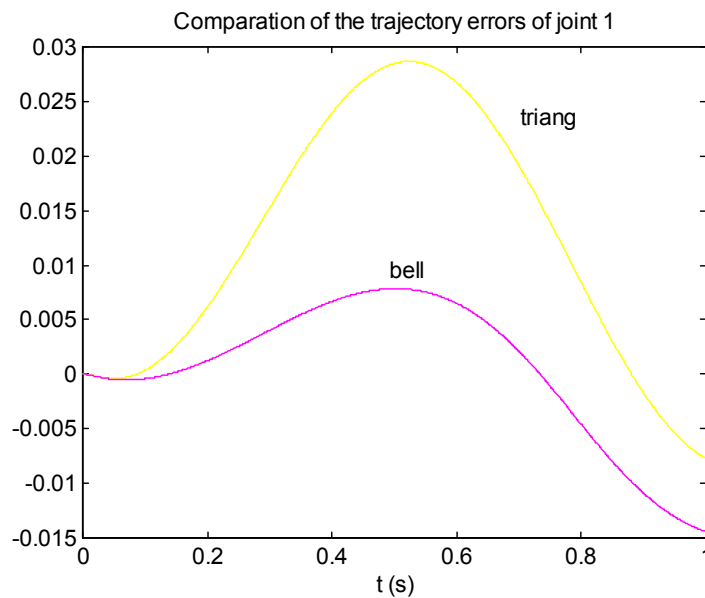

Figure 5. Comparison of the trajectory errors on joint 1.

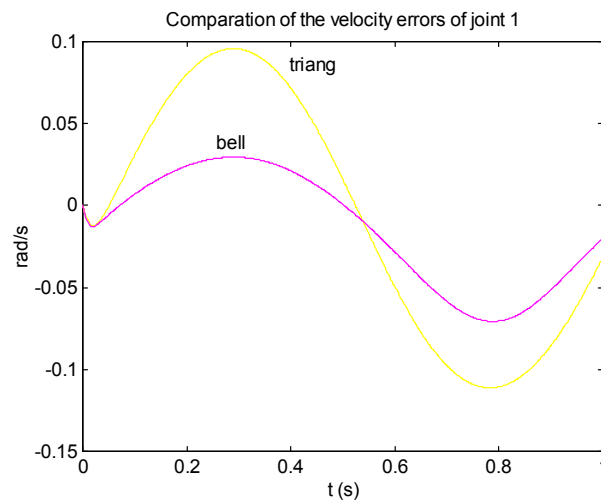

Figure 6. Comparison of the velocity errors on joint 1.

Surface of Fuzzy Controller 1

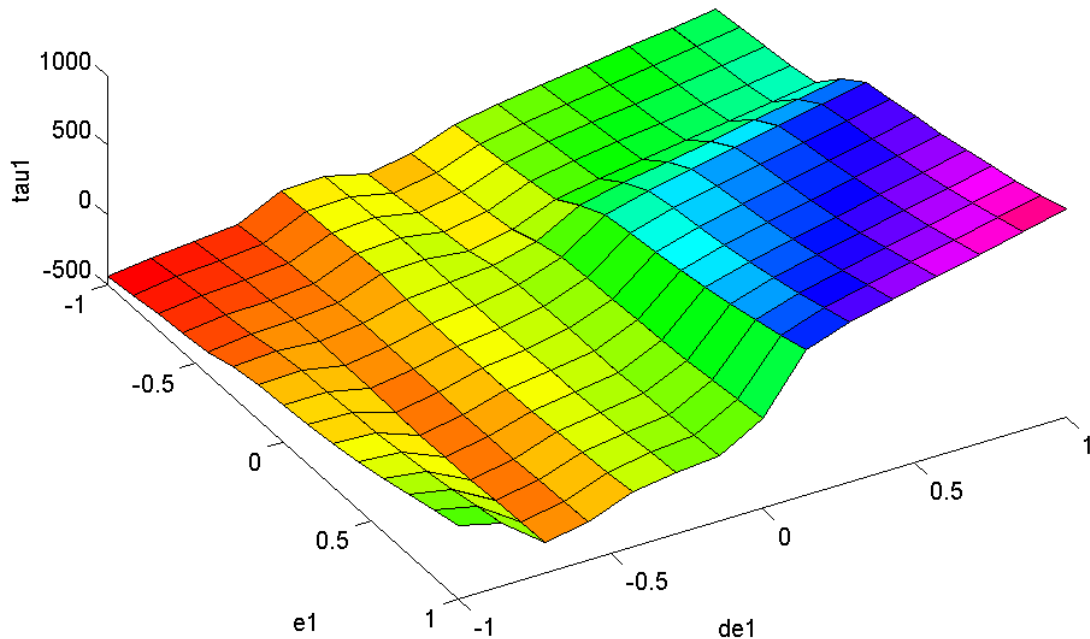

Figure 7. Control surface of the proposed controller.

The Simulink diagram of the 4 DOF SCARA robot control system is shown in Figure 8.

CONCLUSIONS

This article gives the structure optimization of fuzzy control systems based on genetic algorithm in the MATLAB environment. The genetic algorithms are applied for fuzzy rules set, scaling factors and membership functions optimization. The fuzzy control structure consists of the three membership functions and nine rules and it is enough for the 4 DOF SCARA robot control to compensate for structured and unstructured uncertainty.

Fuzzy controller with the generalized bell membership functions can provide better dynamic performance of the robot than with the triangular membership functions. The proposed joint-space controller is computationally simple and had adaptability to a sudden change in the dynamics of the robot.

Results of the computer simulation applied to the 4 DOF SCARA robot show the validity of the proposed method.

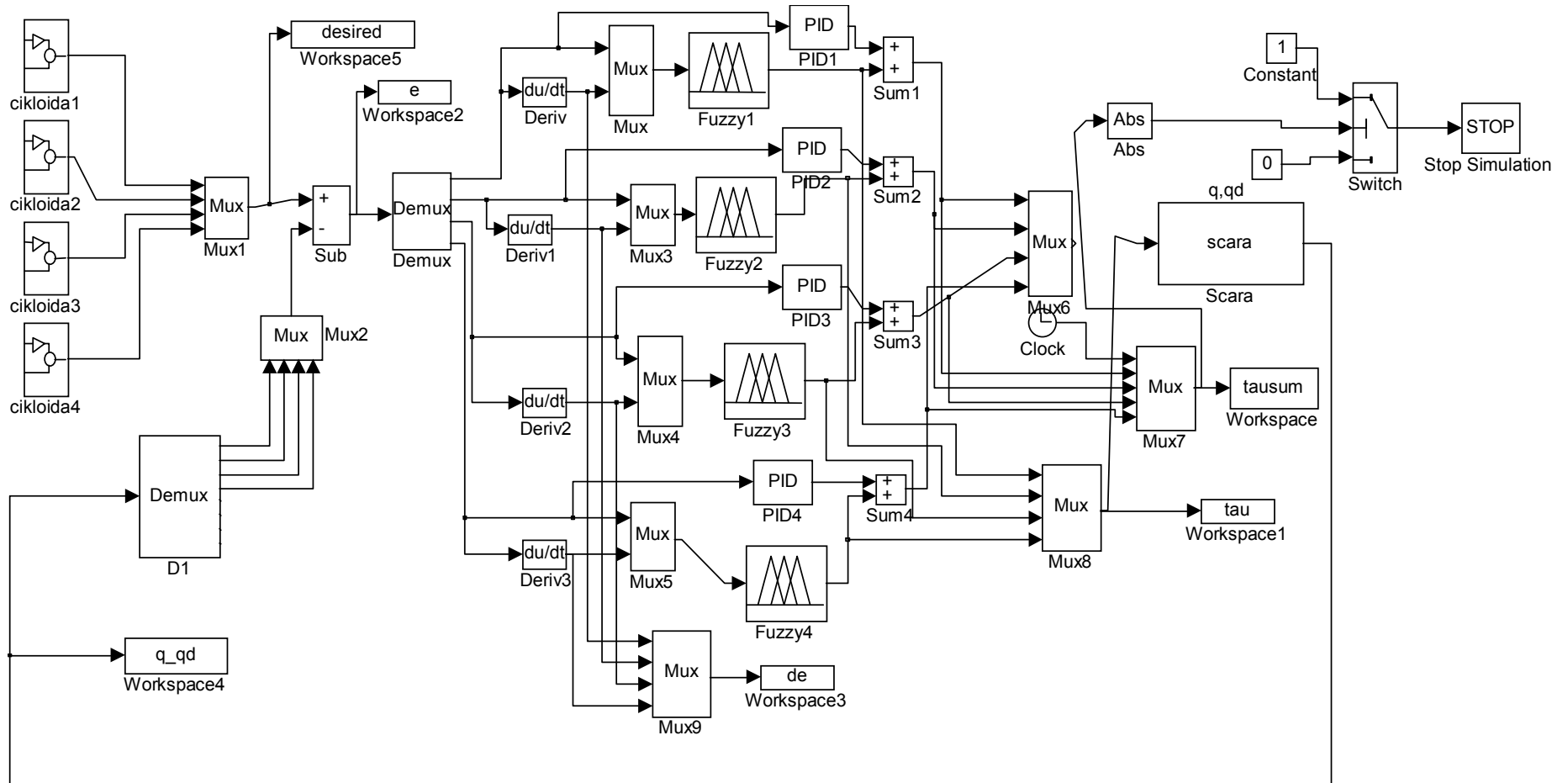

Figure 8. The Simulink diagram of the 4 DOF SCARA robot control system.

REFERENCES

- [1] Mester, Gy. and Pletl, Sz.: *Application of Optimal Fuzzy-Genetic Control for SCARA Type Robot Manipulators*.
Proceeding of the 5th International Workshop on Robotics in Alpe-Adria-Danube Region, RAAD'96, pp.525-528, Budapest, 1996,
- [2] Ishigami, H.; Fukuda, T.; Shibata, T. and Arai, F.: *Structure optimization of fuzzy neural network by genetic algorithm*.
Fuzzy Sets and Systems **71**(3), 257-264, 1995,
- [3] Bíró, I.: *Simple method for solving of planar kinetical problems*.
Proceedings of the International Conference on Science and Technique in the Agri-food Business, ICoSTAF 2012, pp.1-4, Szeged, 2012,
- [4] Bíró, I.; Cszimadia, M.B. and Müller, Z.: *Introduction of computer-aided method in education of mechanics at the Faculty of Engineering in University of Szeged*.
Analecta Technica Szegedinensia, 16-21, 2010/2011,
- [5] Mester, Gy. and Rodic, A.: *Autonomous Locomotion of Humanoid Robots in Presence of Mobile and Immobile Obstacles*.
In: Rudas, I.J.; Fodor, J. and Kacprzyk, J., eds.: *Towards Intelligent Engineering and Information Technology*. Studies in Computational Intelligence, Volume 243, Springer, Berlin and Heidelberg, pp.279-293, 2009,
http://dx.doi.org/10.1007/978-3-642-03737-5_20,
- [6] Mester, Gy.: *Intelligent Mobil Robot Control in Unknown Environments*.
In: Tenreiro Machado, J.A.; Pátkai, B. and Rudas, I.J., eds.: *Intelligent Engineering Systems and Computational Cybernetics*. Springer, Dodrecht, pp.15-26, 2009,
http://dx.doi.org/10.1007/978-1-4020-8678-6_2,
- [7] Rodic, A. and Mester, Gy.: *Sensor-based Navigation and Integrated Control of Ambient Intelligent Wheeled Robots with Tire-Ground Interaction Uncertainties*.
Acta Polytechnica Hungarica **10**(3), 113-133, 2013,
<http://dx.doi.org/10.12700/APH.10.03.2013.3.9>,
- [8] Simon, J. and Martinovic, G.: *Navigation of Mobile Robots Using WSN's RSSI Parameter and Potential Field Method*.
Acta Polytechnica Hungarica **10**(4), 107-118, 2013,
<http://dx.doi.org/10.12700/APH.10.04.2013.4.6>,
- [9] Simon, J. and Matijevics, I.: *Autonomous Mobile Robot as a Measuring Station in Controlled Microclimatic Environment*.
Proceedings of the XXVI. International Kandó Conference 2011, Science in Practice, pp.1-9, Budapest, 2011,
- [10] Simon, J. and Matijevics, I.: *Simulation and Implementation of Mobile Measuring Robot Navigation Algorithms in Controlled Microclimatic Environment Using WSN*.
Proceedings of the IEEE 9th International Symposium on Intelligent Systems and Informatics – SISY 2011, pp.275-279, Subotica, 2011,
<http://dx.doi.org/10.1109/SISY.2011.6034337>,
- [11] Ćosić, J.; Ćurković, P.; Kasać, J. and Stepanić, J.: *Interpreting Development of Unmanned Aerial Vehicles Using Systems Thinking*.
Interdisciplinary Description of Complex Systems **11**(1), 143-152, 2013,
<http://dx.doi.org/10.7906/indecs.11.1.12>,
- [12] Stepanic, J.; Mester, Gy. and Kasac, J.: *Synthetic Inertial Navigation Systems: Case Study of Determining Direction*.
Proceedings of 57th ETRAN Conference, pp.RO 2.7.,1-3, Zlatibor, 2013,

- [13]Stepanic, J.; Kasac, J. and Cosic Lesicar, J.: *What is Taken for Granted about Quadrotors: Remarks about drive and communication.*
Proceedings of the 3rd International Workshop on Advanced Computational Intelligence and Intelligent Informatics – IWACIII 2013, pp.1-4, Shanghai, 2013.
-

DIZAJN NEIZRAZITOG UPRAVLJAČKOG SUSTAVA ZA INTELIGENTNE ROBOTI, TEMELJENOG NA GENETSKOM ALGORITMU

Gyula Mester

Sveučilište u Szegedu – Fakultet inženjerstva
Szeged, Mađarska

SAŽETAK

Rad razmatra strukturno optimiranje sustava neizrazite kontrole. Optimiranje se temelji na genetskim algoritmima u okruženju programskog paketa MATLAB. Genetski algoritam je korisni alat za strukturno optimiranje neizrazitih kontrolera zbog čega je u ovom radu predložena integracija i sinteza genetskog algoritma i neizrazite logike. Genetski algoritam primijenjen je na skup neizrazitih pravila, faktore skaliranja i optimiranje funkcija članova. Početna struktura neizrazitog kontrolera uključuje 3 funkcije članova i 9 pravila. Nakon optimiranja to je dovoljno da u kontroli robota SCARA s 4 stupnja slobode kompenzira strukturne i nestrukturne nepouzdanosti. Neizraziti kontroler s poopćenom zvonolikom funkcijom članova omogućuje bolja dinamička svojstva robota nego neizraziti kontroler s poopćenom trokutastom funkcijom članova. Predloženi kontroler komputacijski je jednostavan i prilagodljiv naglim promjenama dinamike robota. Rezultati računalne simulacije primijenjeni na robot SCARA s 4 stupnja slobode dokazuju validaciju predložene metode.

KLJUČNE RIJEČI

genetski algoritmi, MATLAB okruženje, optimiranje strukture, neizraziti kontroler, SCARA robot s 4 stupnja slobode